

**INSTRUCTIONS BOOK**

**PRADA NARGESA, S.L**

Ctra. de Garrigàs a Sant Miquel s/n

17476 PALAU DE STA. EULALIA (GIRONA) SPAIN

Tel. 972 568085

[www.nargesa.com](http://www.nargesa.com) - [nargesa@nargesa.com](mailto:nargesa@nargesa.com)



[www.nargesa.com](http://www.nargesa.com)

Thank you for choosing our machines



**THERE IS A DVD INCLUDED  
AS AN ESSENTIAL PART OF  
THIS BOOK.**

**IT'S GOT THE STEP-BY-STEP  
PERFORMANCE OF THE  
MACHINE AND SOME  
EXAMPLES OF WORKS  
THAT CAN BE CARRIED  
OUT WITH IT.**

**INDEX**

<b>1. MACHINE INFORMATION</b> .....	2
1.1 Identification of the machine. ....	2
1.2 Normal use of the machine .....	2
1.3 Contraindications of use.....	2
1.4 Noise caused by the machine .....	2
1.5 Vibrations. ....	2
1.6 Operative natural working place. ....	2
1.7 Description of the machine .....	2
1.8 Descripción de los accesorios. ....	3
1.9 Description of safety devices .....	3
1.10 Basic features of the tooling.....	3
1.11 Information related to the electrical equipment.....	3
<b>2. TRANSPORT, MAINTENANCE AND STORAGE.</b> .....	5
2.1 Storage conditions .....	5
2.2 Transportation .....	5
2.3 Dimensions.....	5
<b>3. INSTALLMENT AND STARTING UP</b> .....	6
3.1 Instructions to set it up .....	6
3.2 Assembling to reduce noise and vibrations .....	6
3.3 Instructions for assembling and .....	6
3.4 Admissible outer conditions .....	6
3.5 Instructions for the connection to power supply.....	6
3.6 Safety systems for the user.....	6
<b>4. INSTRUCTIONS FOR THE USAGE</b> .....	7
4.1 Instructions for adjustment. ....	7
4.2 Waste hazards .....	7
4.3 Information about forbidden methods of use. ....	7
4.4 Instructions for locating breakdowns and the further rearming of the machine. ....	7
4.5 Principles for bending.....	8
4.6 Mounting the rollers.....	8
<b>5. ASSEMBLING THE ROLLERS</b> .....	10
5.1 Axes traction of the machine.....	10
5.2 Rollers for standard pipes.....	10
5.3 Capacidad de curvado.....	11
5.4 Different samples of bending .....	12

**TECHNICAL ANNEX**

## **1. MACHINE INFORMATION**

### **1.1. Identification of the machine.**

Trademark : NARGESA

Type: Curvadora

Model: MC 400-9

### **1.2. Normal use of the machine.**

The profile former has been designed for bending profiles, pipes, angles, etc... At different dimensions and different kinds of materials.

A set of standard tooling is provided with the machine, with which you will be able to bend the different profiles. Anyhow the manufacturer can provide you with any kind of roller so you can make other kinds of bendings as well as Delring rollers to avoid damaging the works in inox or aluminium.

**If an accident occurs due to a negligent use on the operative's side, for not following the safety rules exposed on this book, PRADA NARGESA S.L will not accept any responsibility.**

### **1.3. Contraindications of use**

Every use different from the one for bending of materials.

### **1.4. Noise caused by the machine.**

In this particular case the noise is almost non-existent under normal working conditions.

### **1.5. Vibrations**

Like noise, vibrations could be considered non-existent since this is a fixed machine and besides it has a low rotary speed on the rollers.

### **1.6. Operative natural working place.**

The machine can be used just by only one worker at the time, who will be located in front of the machine so it can regulate the movement of the three moveable axes.

### **1.7. Description of the machine.**

The machine is equipped with a 1,1 Kw power and the reducer that transmits rotation to the three axes through cogged crowns. These are steel treated and rectified axes 40mm diameter

The machine has two shelves below where there is the engine to keep the tooling, the machine structure is made of welded and mechanized steel sheet which gives the machine a strong and solid structure.

### TECHNICAL CHARACTERISTICS

Power	1,1KW/1,5CV (HP)
Tensión 3 phases	230V/400v
Speed	7 r.p.m
Shafts diameter	40mm
Roller diameter	130mm
Useful shafts length	80mm
Dimensions	650x7740x1260mm
Weight	365Kg

#### 1.8. Description of accessories

The basic accessories the machine has are a set of 9 standard rollers with three thick parts, three fastening threads and three washers, one for each axel.

#### 1.9. Description of safety devices

The gear and moveable parts are covered with the exception of the working part of the rollers in the frontal part.

#### 1.10. Basic characteristics of the tooling that can be adjusted to the machine

The caution to bear in mind with accessories to be adjusted to the machine is that they all have to coincide in the kind of clamping to the machine and they cannot be loosen. Be always careful not to fix the threads with the hands.

#### 1.11. Information related to the electrical equipment.

The machine has a 230/400 V three phased engine, connected in star when the line tension is 400 v and connected in triangle when the three phased line tension is 230 v, as it is indicated below:

Star connection, when the line tension is 400v (preset):

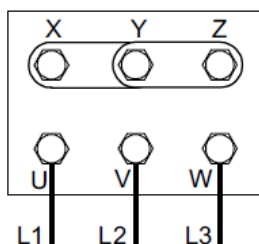

*Star connection, when the line tension is 400v (preset)*

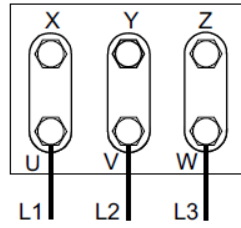

*Connection in triangle, when the line tension is 230v*

As well, it is necessary to change the input terminals of the inverter for the change of tension. Input 400V. (Terminals "0" and "400"). Input to 230 V. (Terminals "0" and "230").

In order to detail the procedure, please see the sketch.

## 2. TRANSPORT, MAINTENANCE AND STORAGE.

### 2.1. Storage conditions

The machine must be stored in places with the following requirements:

- Humidity between 30% and 95% without condensation.
- Temperature from  $-25^{\circ}\text{C}$  to  $+55^{\circ}\text{C}$  or  $+75^{\circ}\text{C}$  for periods no longer than 24 h.
- It is advisable not to pile up machines nor heavy objects on top of them.
- Do not dismantle for storage.

### 2.2. Transport

Transportation must be carried out by using a forklift truck.

### 2.3. Dimensions

Weight: 365 Kg

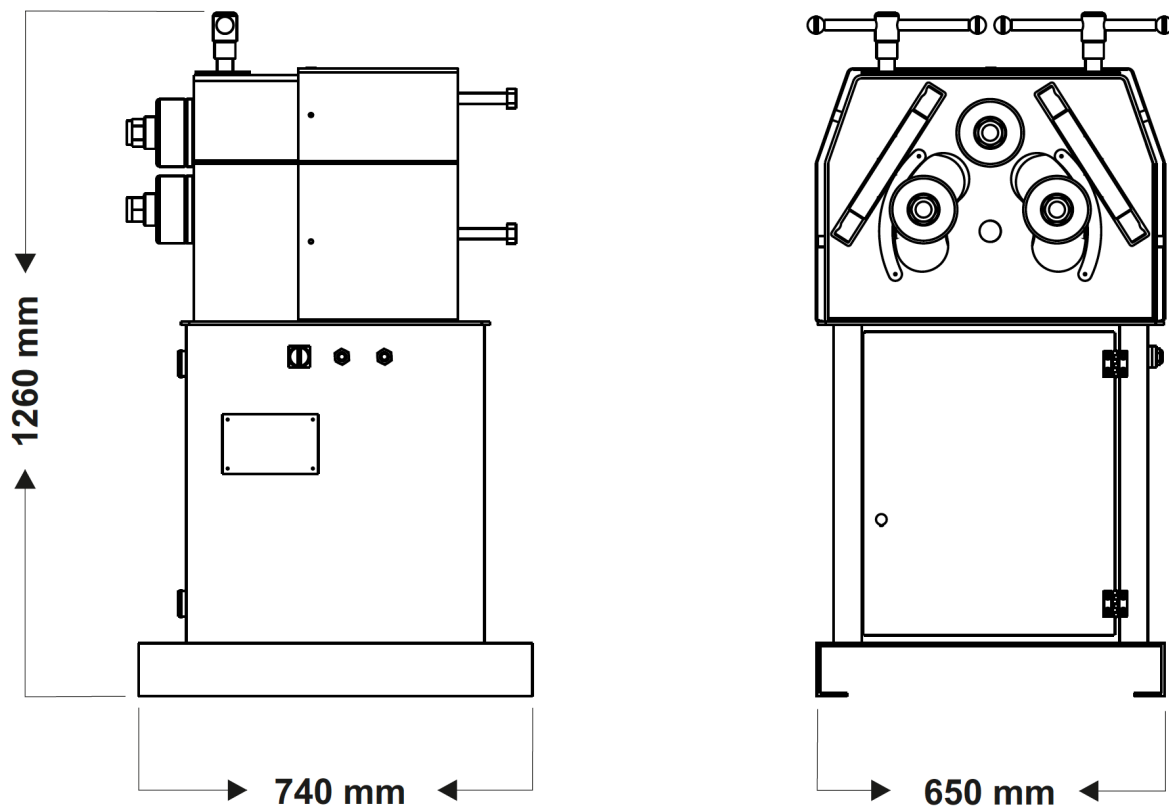



### **3. INSTALLMENT AND STARTING UP**

#### **3.1. Instructions to set it up:**

When the machine is put down by the crane it will be necessary to put it correctly so it doesn't have to be moved once it is on the floor. If it isn't possible then it has to be put on a moveable base to move it into a proper place.

The machine will be fixed by its own weight on the floor that's why it has to be set on a flat surface.

#### **3.2. Assembling to reduce noise and vibrations**

This machine has a very low level of noise and vibrations, due to its low speed.

#### **3.3. Instructions for the assembling and dismantling**

The machine is transported completely assembled.

#### **3.4. Admissible outer conditions**

Environmental temperature Between: +5°C and +40°C without exceeding as average temperature during 24h. Do not go beyond +35°C. Humidity: Between 30% and 90% without water condensation.

#### **3.5. Instructions to connect the machine to the power supply**

It must be connected to only one power supply in the indicated power source. If the line tension is not correct, then the engine bobins must be replaced.

It is very important to connect the machine properly to a ground socket

#### **3.6. Safety systems for the user.**

Never touch the rollers when they are bending material for the damage they can cause, there might be risk of hands smashing.

The place to locate the machine must be selected taking into account the room it will occupy the metal bar during the performance of the operation.

## **4. INSTRUCTIONS FOR THE USAGE**

### **4.1. Instructions for the adjustment.**

This machine has not got any adjustable element, with the exception of any kind of repair.

### **4.2. Waste danger (That cannot be eliminated). Hazard caused by adjusted elements.**

Always keep in mind that hands must not be placed in the roller moveable parts of the rollers since there might be risk of cutting out the fingers, hands or arms.

The machine performance place must be protected to prevent the operative from any possible damage with the bent material.

### **4.3. Information about forbidden methods of use.**

Do not use tooling that are not provided by the manufacturer as a way to avoid the breakdown of any element that could injure the user.

### **4.4. Instructions for locating breakdowns, repair and rearming of the machine.**

Due to its simple mechanism, this machine does not tend to breakdowns. The only possible one could be the handling fuse change in the electric box. This is located in the back part of the machine. In order to replace it, the machine must be unplugged and the back cover where the reducer is, must be removed. There will be a white PVC box where the electric handling and the protection fuse. In case you need to substitute one, it is advisable to put one of the same value.

#### 4.5. Principles to bend

- The activation of the machine engine is carried out by using the pedals, one to turn right and the other one to turn left, without nailing in.
- It is necessary to get the side rollers up or down in order to regulate the bending radius, and do the same with the vertical rollers in order to achieve the torsion.
- Activation pedals have no nailing in. So the machine will stop when the pedal is not pressed.
- For the emergency stop, press the pedal emergency button.
- The material can be put in the machine for both places. Use the upper handling to adjust the entrance of material. Use the millimeter scale to indicate the position.
- Adjust the approximate height to both lateral rollers to get a given radius, (the more you do it, the more experienced you will get).
- Adjust the two vertical stand rollers. This will be adjusted by the back part, getting them closer or farther from the profile that has been already set in the rollers. They will help us control the lateral distortion. (They must be adjusted so they get to slightly touch the profile).
- If the profile to be worked does not fit in the rollers, it is advisable to cut the extreme to give it a wedge shape, to ease its entrance.
- In case the desired results are not achieved, then modify the side rollers position and the vertical ones.
- The fastening nuts of the rollers must be only tightened with the hands strength. (no fastening tooling is required to do that).
- It is advisable to put some oil in the up and down threads of the rollers whenever necessary to avoid them from getting any hardness.

#### 4.6. Assembling of rollers

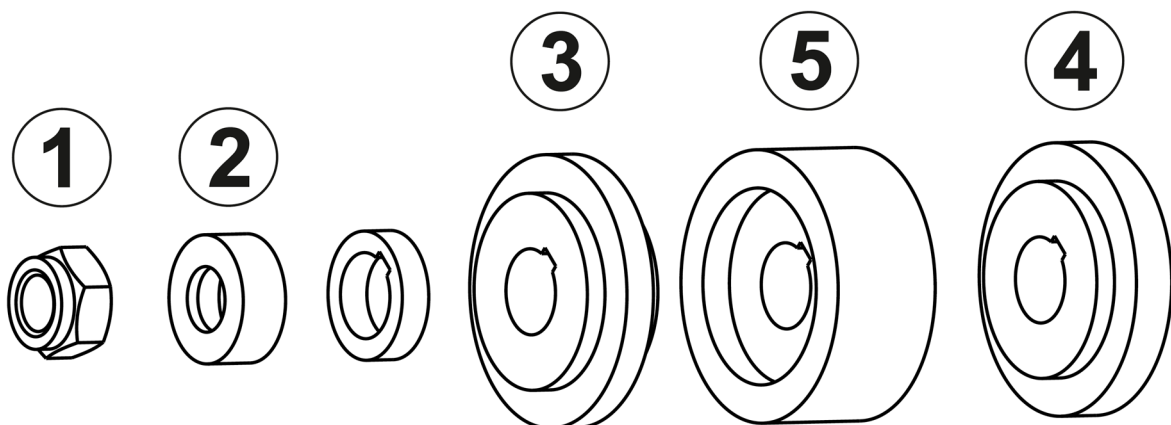

**5. ASSEMBLING OF THE ROLLERS**

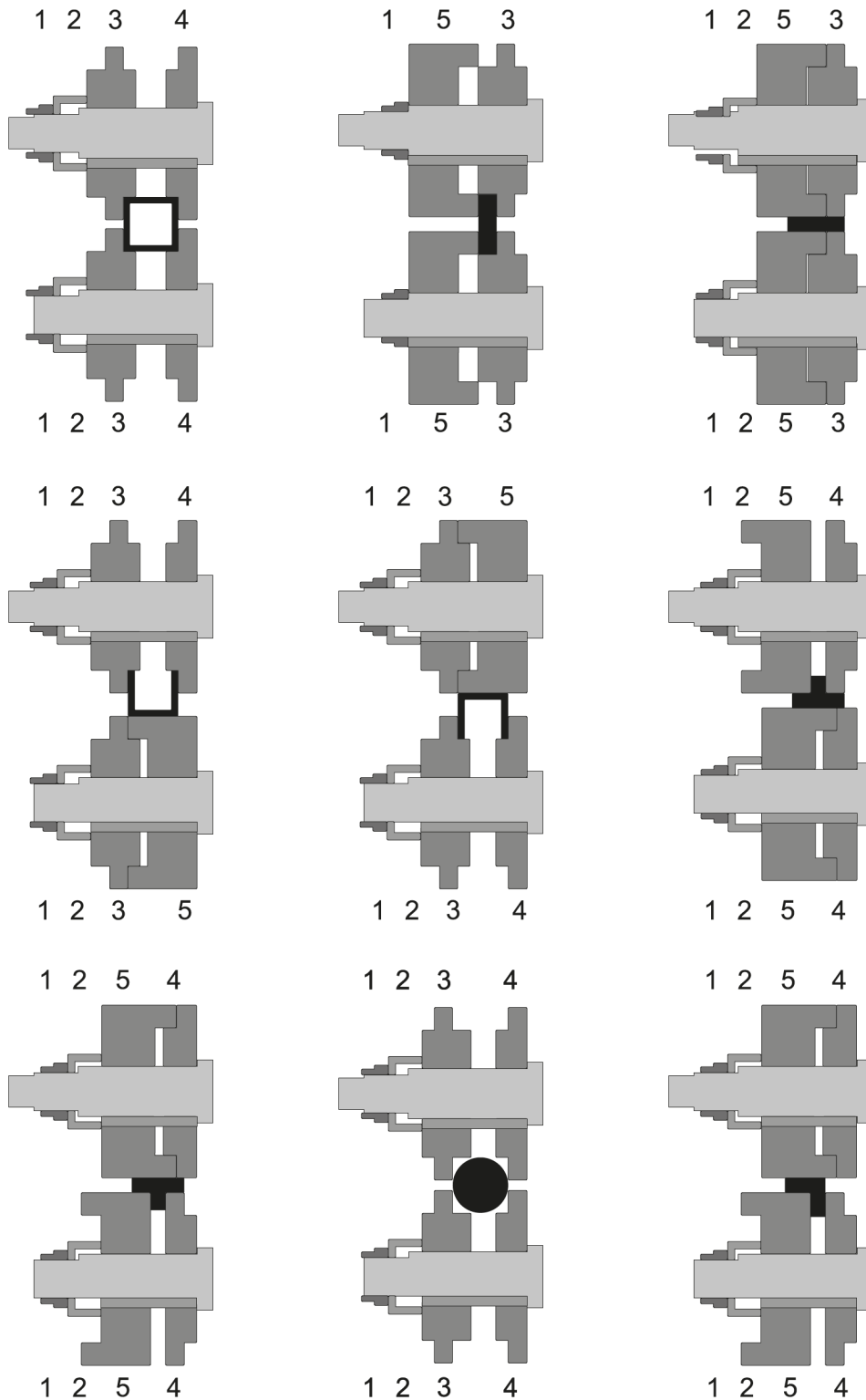

*Nomenclature of the rollers and assembly*

**IMPORTANT NOTE:**

The clamping nut of the rollers should never be tightened with a wrench and only by hand. If pipe rollers are being used, the nuts must be loose.

### 5.1. Traction of the machine axels

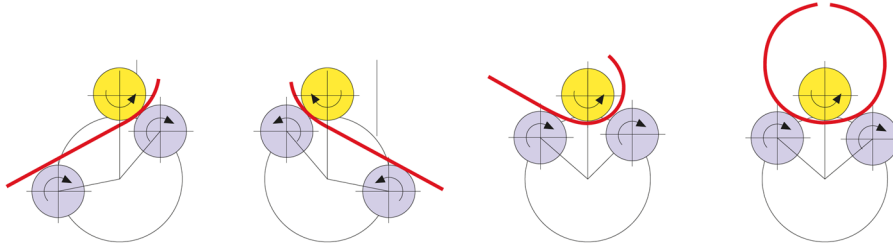

### 5.2. Rollers for standard pipes.

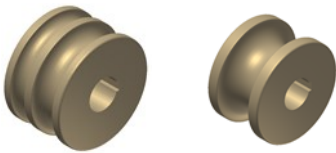

Set of 3 tempered steel rollers for round pipe

For pipe					
in mm	Weight	ISO in mm	Weight	Whitwort inches	Weight
(30+25)	17,00 Kg	(26,9+21,3)	17,70 Kg	$(1/2''+1''1/4'')$ = (12,700 + 31,751 mm)	18,00 Kg
(35+20)	16,50 Kg	(33,7+17,2)	17,00 Kg	$(1''+3/4'')$ = (25,401 + 19,051 mm)	18,50 Kg
40	16,60 Kg	42,4	16,00 Kg	$1''1/2$ = 38,101 mm	17,25 Kg
50	14,25 Kg	48,3	14,40 Kg	$2''$ = 50,802 mm	13,60 Kg
60	11,10 Kg	60,3	11,15 Kg	$2''1/2$ = 63,502 mm	9,75 Kg
70		76,1		$3''$ =76,2 mm	



Set of 3 Sustarin rollers for stainless steel, aluminium tubes and delicate materials with a thickness less than 2.5 mm.











#### For pipe in mm.

(25+30) - (20+35) - 33 - 40 - 43 - 50 - 50,8 - 60

*For any other size or profile please ask the manufacturer.*

### 5.3. Bending capacity

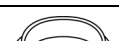
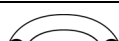

Profile	MC150B		MC200		MC400		MC200H		MC650	
	Measures	Min. radius	Measures	Min. radius	Measures	Min. radius	Measures	Min. radius	Measures	Min. radius
	50 x 8	300	50 x 10	300	50 x 10	250	60 x 10	200	100 x 20 80 x 20	1250 450
	60 x 20	200	80 x 20	150	80 x 20	150	80 x 20	150	100 x 25 80 x 20	350 200
	25 x 25	200	30 x 30	200	30 x 30	150	30 x 30	150	45 x 45 25 x 25	300 200
	40 x 40 x 3	350	50 x 50 x 3	700	50 x 50 x 3	600	50 x 50 x 3	450	70 x 70 x 4 40 x 40 x 3	750 350
	40	200	40	200	40	150	40	200	80 * 70 40	500 400 150
	40	250	40	250	40	200	40	250	80 * 60 40	500 400 150
	50	200	60	300	60	225	60	225	120 * 100 * 80	600 600 400
	50	250	60	300	60	225	60	225	120 * 100 * 80	700 700 400
	40	500	40	420	40	200	40	300	70 40	600 250
	25	180	30	150	30	150	30	150	50 25	300 175
	40 x 2 * 50,8 x 3 * = 2" x 3 *	300 600 600	40 x 2 * 63,5 x 3 * = 2 1/2" x 3 *	250 500 500	40 x 2 * 63,5 x 3 * = 2 1/2" x 3 *	200 450 450	40 x 2 * 76,2 x 2 * = 3" x 2 *	200 500 500	88,9 x 4 * 101,6 x 3 * = 4" x 3 *	700 700 700

\* Optional rollers

#### 5.4. Different samples of bending

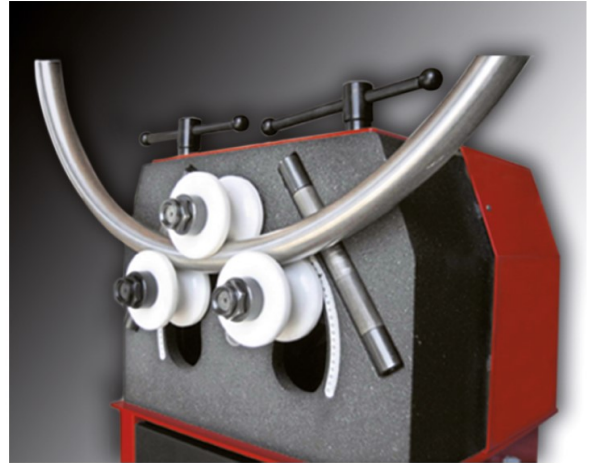
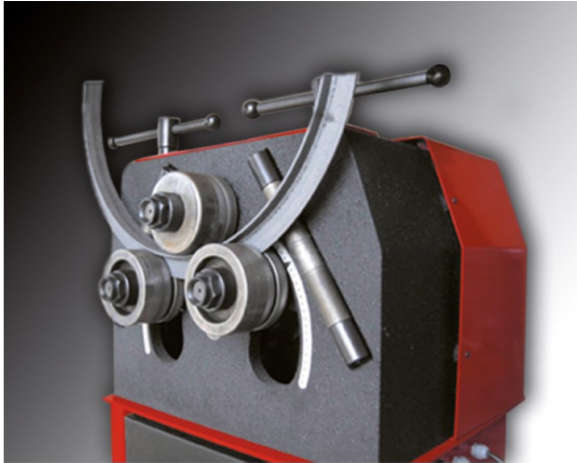
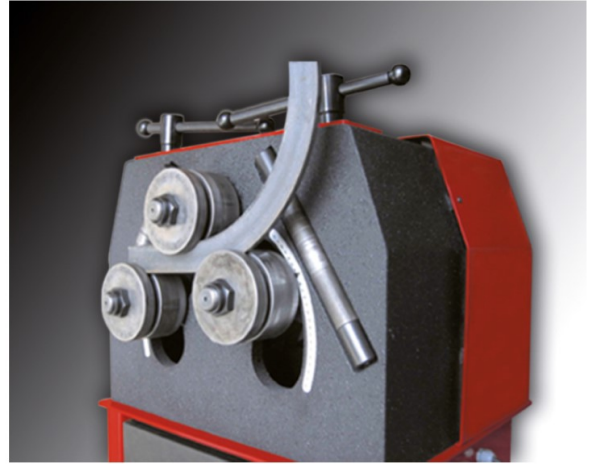
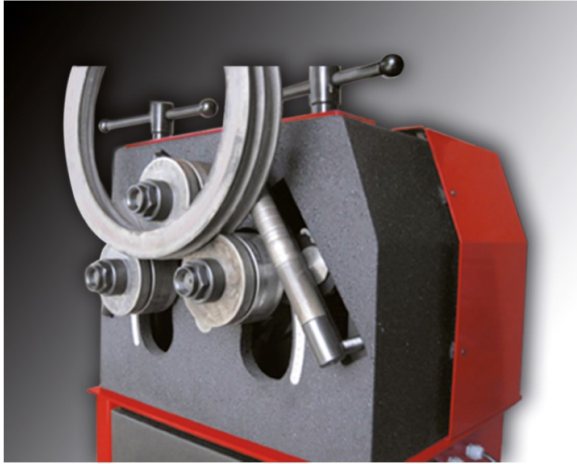

## **Technical annex**

### **MC200 Bending Machine**

---

General Parts Diagram

Elcetric map



**A1 General parts diagram**

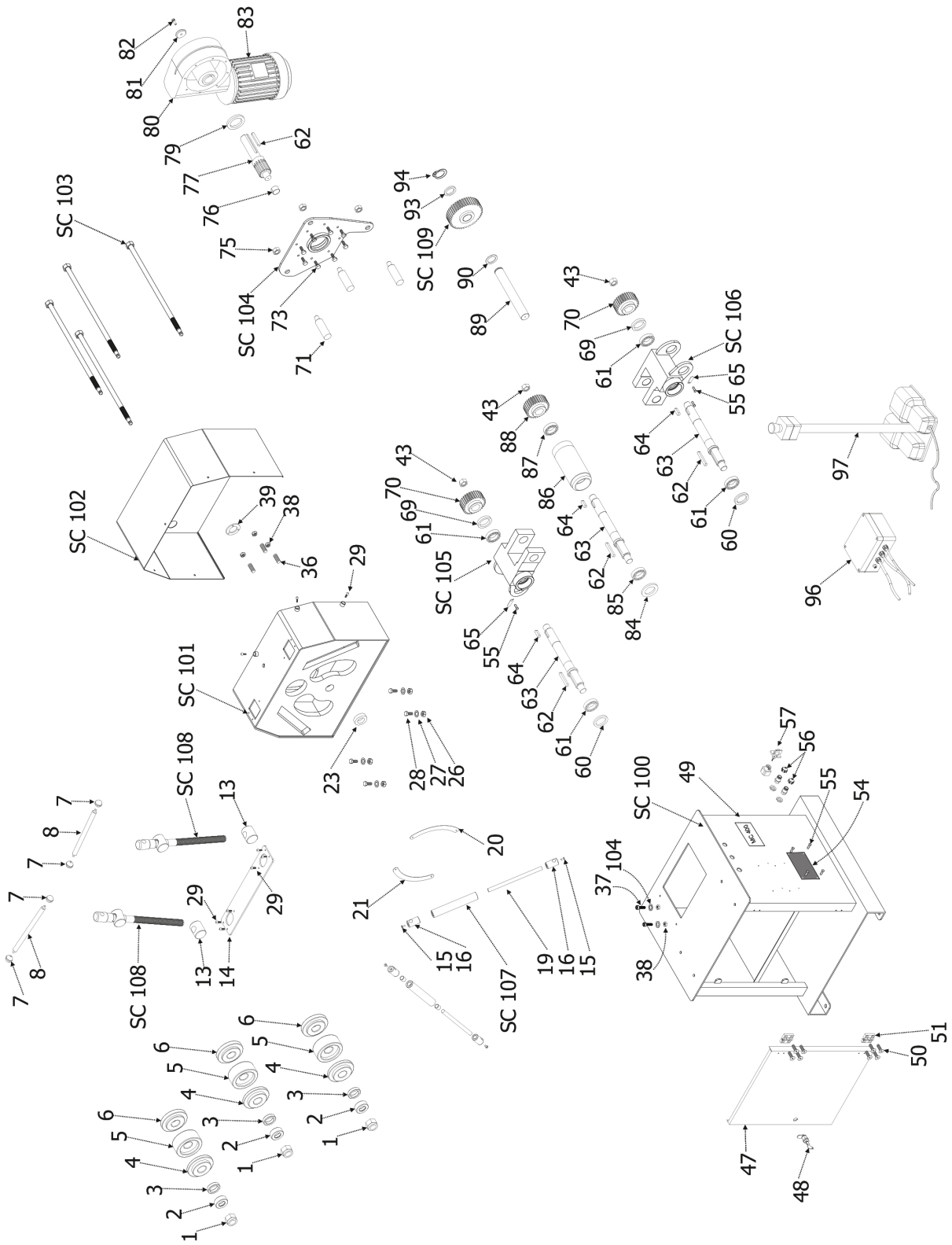

**A2 Electrical map**

In case the machine has to be connected to a three phased 230V socket the terminals of the engine must be changed and the wire to the 415V input must be put into the input for 230V of the inverter.

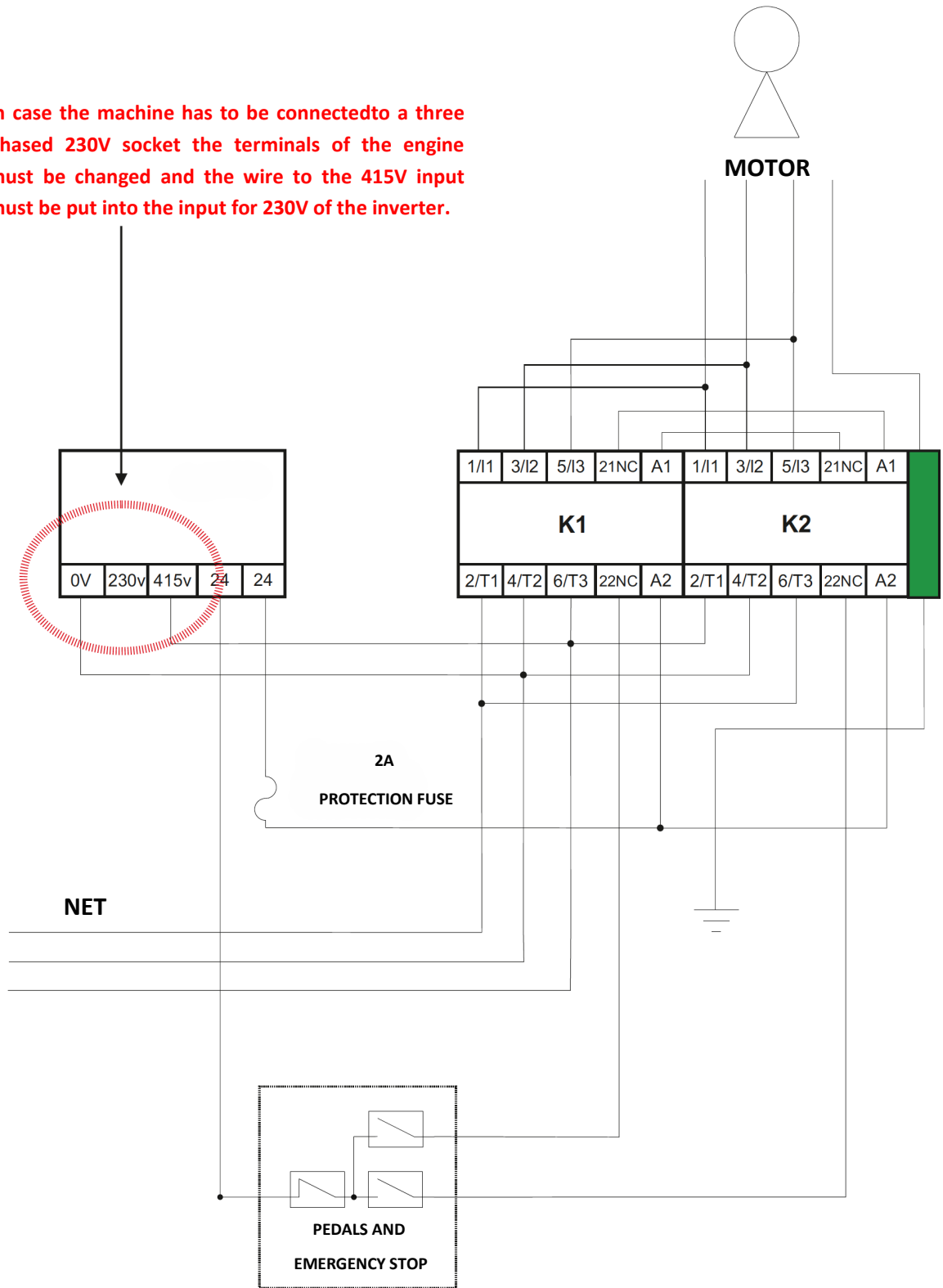

## WARRANTY REGISTRATION

1. Among [www.nargesa.com](http://www.nargesa.com) on our site

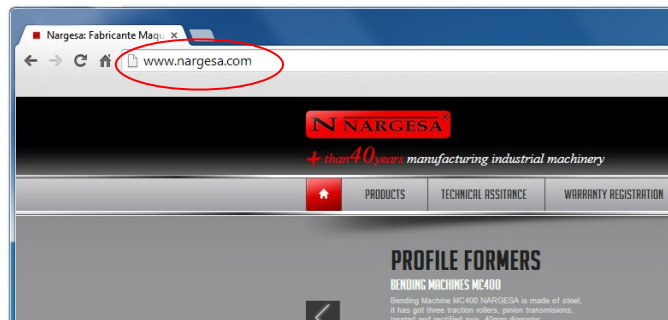

2. Select the menu **Warranty Registration**

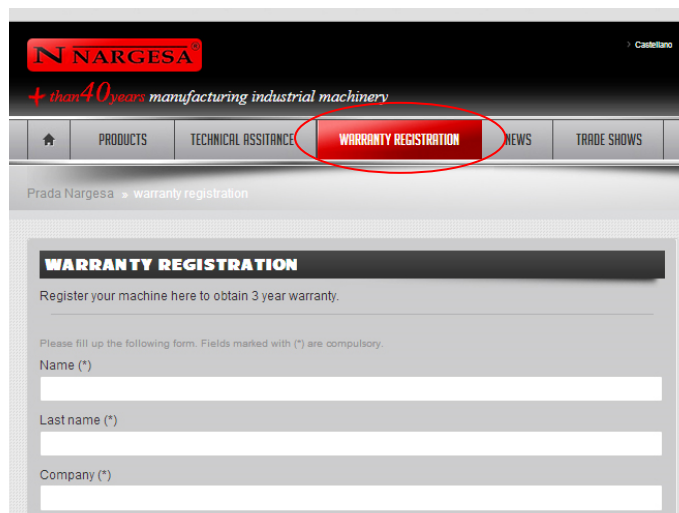

3. Complete the form with your details and press **Send**



4. The window **Message Sent** confirms your data has been successfully sent to Prada Nargesa SL. Your machine has been registered and has a warranty of three years in total.

